

MECCANO[™]
ENGINEERING & ROBOTICS

HURACAN
Spyder

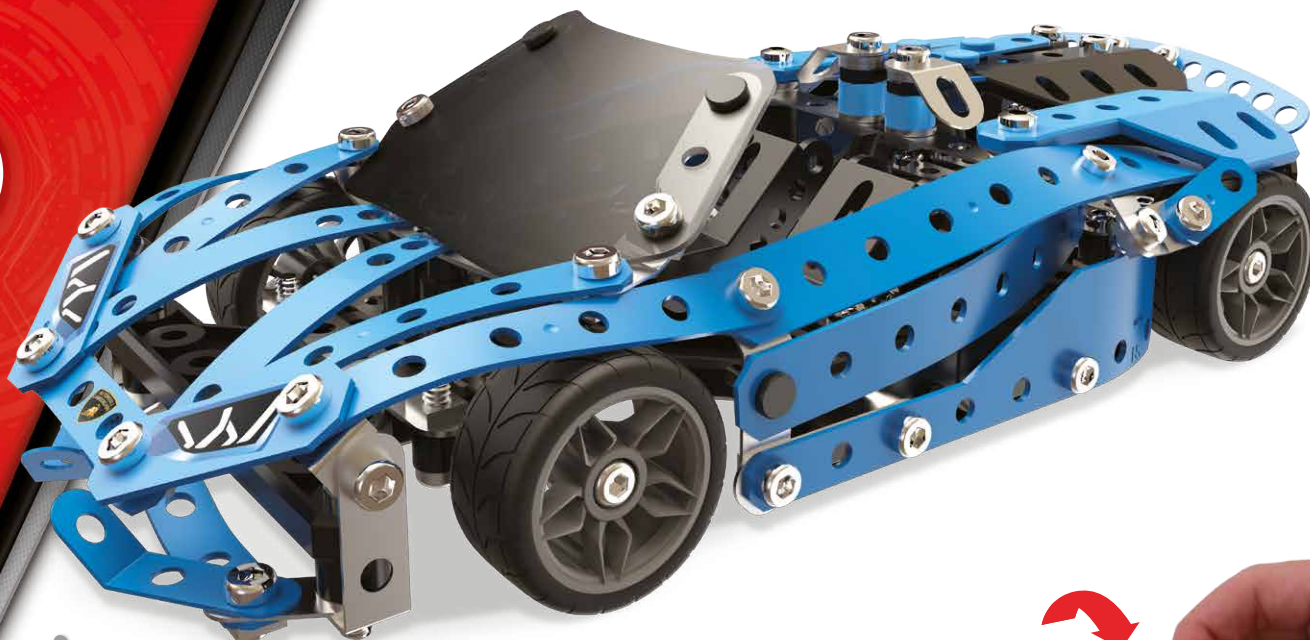

17302



10+

Instructions
Notice de montage
Instrucciones de construcción
Bauanleitung

Bouwinstructie
Istruzioni
Instruções
Инструкции

Instrukcja
Pokyny
Útmutató
Instrucțiuni





CONSTRUCTION TIPS / ASTUCES DE CONSTRUCTION

TIPS DE CONSTRUCCIÓ / TIPPS ZUM BAUEN / MONTAGETIPS / SUGGERIMENTI PER COSTRUIRE
DICAS DE MONTAGEM / РЕКОМЕНДАЦИИ ПО СБОРКЕ / WSKAZÓWKI BUDOWANIA
KONSTRUKČNÍ TIPY / TIPY NA MONTÁŽ / ÖSSZESZERELÉSI TIPPEK / SFATURI PENTRU CONSTRUIRE

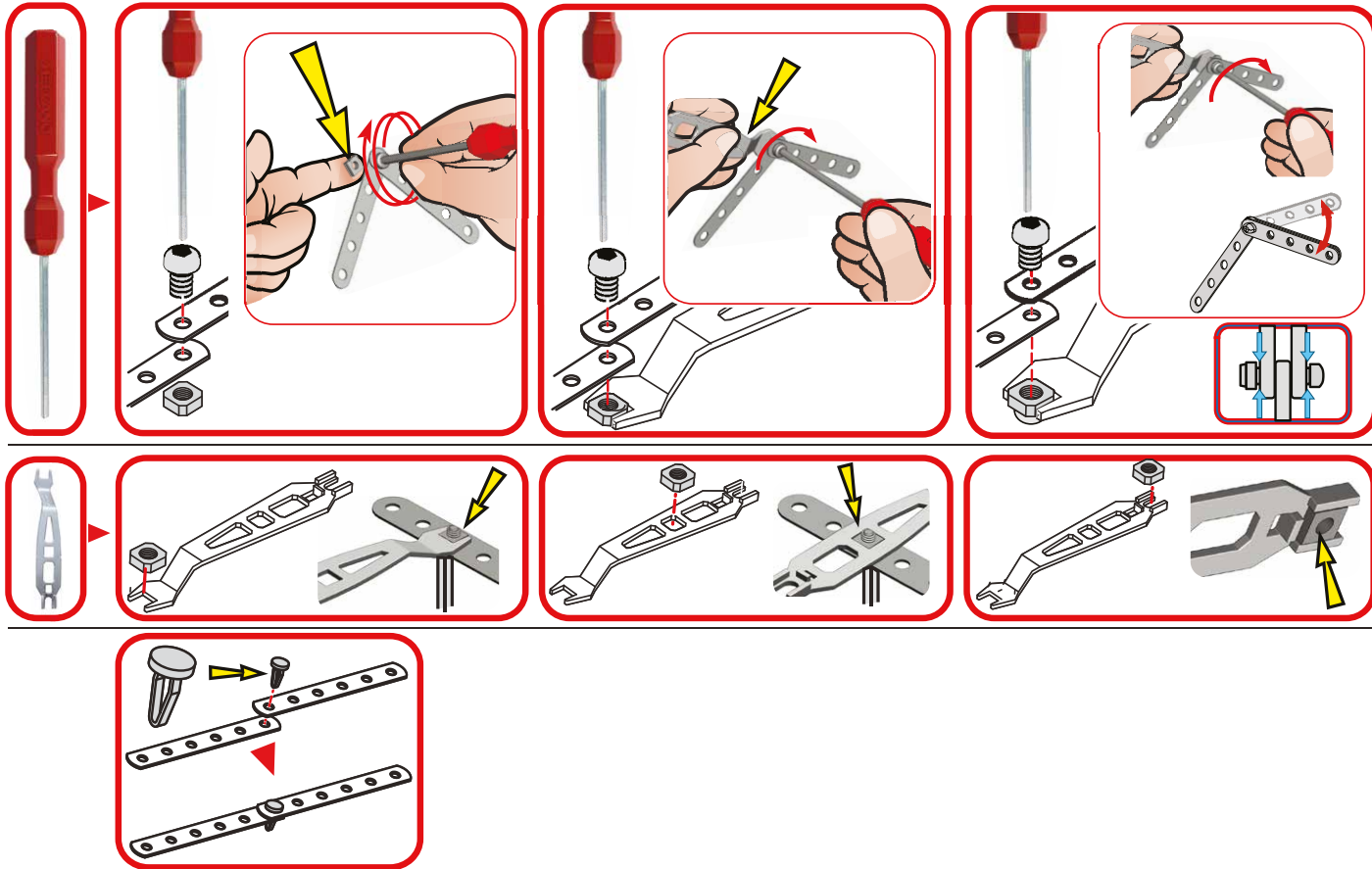
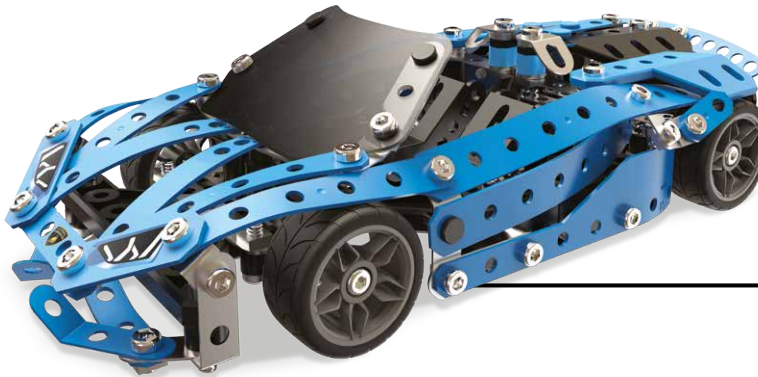

TABLE OF CONTENTS / SOMMAIRE

ÍNDICE / INHALTSVERZEICHNIS / INHOUD / INDICE / СОДЕРЖАНИЕ

SPIS TREŚCI / OBSAH / TARTALOMJEGYZÉK / CUPRINS



- EN.** Content: 259 parts, 2 real tools, 1 sticker sheet, 1 instruction sheet for 1 model.
- FR.** Contenu : 259 pièces, 2 vrais outils, 1 feuillet d'autocollants, 1 notice de montage pour 1 modèle.
- ES.** Contenido: 259 piezas, 2 herramientas reales, 1 hoja de calcomanías, 1 guía de instrucciones para 1 modelo.
- DE.** Inhalt: 259 Teile, 2 echte Werkzeuge, 1 Bogen mit Aufklebern, 1 Bauanleitung für 1 Modell.
- NL.** Inhoud: 259 onderdelen, 2 stuks gereedschap, 1 stickervel, 1 bouw instructie voor 1 model.
- IT.** Contenuto: 259 pezzi, 2 attrezzi, 1 foglio di adesivi, 1 guida per l'uso per 1 modello.
- PT.** Conteúdo: 259 peças, 2 ferramentas reais, 1 cartela de adesivos, 1 folha de instruções para 1 modelo.
- RU.** В комплекте: 259 деталей, 2 настоящих инструмента, 1 лист с наклейками, 1 инструкция по сборке 1 модели.
- PL.** Zawartość: 259 elementów, 2 prawdziwe narzędzia, 1 karta z naklejkami, 1 karta z instrukcjami dla 1 modelu.
- CZ.** Obsah: 259 dílů, 2 skutečné nástroje, 1 list se samolepkami, 1 list s pokyny pro 1 model.
- SK.** Obsah: 259 dielov, 2 skutočné nástroje, 1 hárok s nálepkami, 1 hárok s pokynmi pre 1 model.
- HU.** Tartalom: 259 db alkatrészt, 2 db valódi szerszám, 1 db matricapapír, 1 db 1 modellhez tartozó felhasználói útmutató.
- RO.** Conținut: 259 de piese, 2 instrumente reale, 1 foaie cu autocolante, 1 fișă cu instrucțiuni pentru 1 model.

- ⚠ CAUTION: Stickers not intended to be placed on skin.
- ⚠ MISE EN GARDE : Les autocollants ne sont pas destinés à être placés sur la peau.
- ⚠ PRECAUCIÓN: Las calcomanías no deben colocarse sobre la piel.
- ⚠ ACHTUNG: Sticker sind nicht zum Aufkleben auf die Haut geeignet.
- ⚠ VOORZICHTIG: Stickers zijn niet voor op de huid bedoeld.
- ⚠ ATTENZIONE: Non applicare gli adesivi sulla pelle.
- ⚠ CUIDADO: Não aplique os adesivos na pele.
- ⚠ ОСТОРОЖНО: Стикеры не предназначены для приклеивания к коже.
- ⚠ OSTRZEŻENIE: Naklejki nie należy umieszczać na skórze.
- ⚠ POZOR: Samolepky nejsou určeny k lepení na kůži.
- ⚠ UPOZORNENIE: Nálepky nie sú určené na nalepenie na pokožku.
- ⚠ VIGYÁZAT! A matricák nem alkalmasak a bőrre történő ragasztásra.
- ⚠ ATENȚIE: Autocolantele nu sunt destinate lipirii pe piele.



1

	S2	9,5 mm	x4
		3/8"	x4
			x2
			x1
			x1



	S2	1:1
--	----	-----

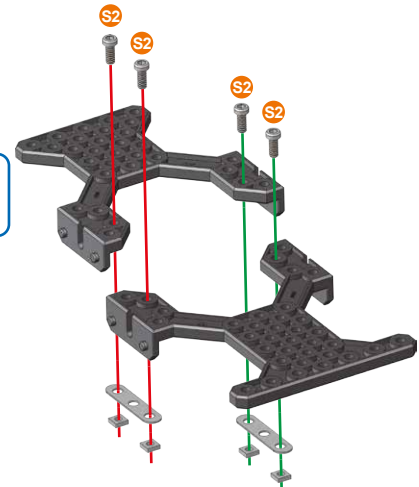
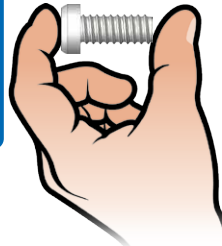

2

			x2
	S1	5,8 mm	x2
		15/64"	x2
			x2

	S1	1:1
--	----	-----

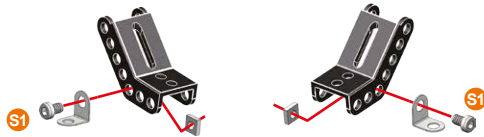

3

① + ② +

	S1	5,8 mm	x2
		15/64"	x2
	S1	1:1	

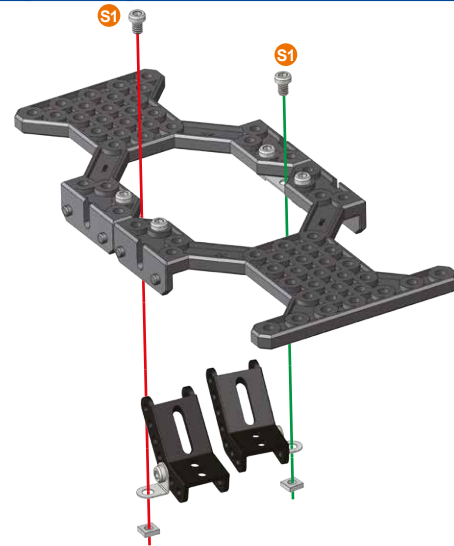

4

	x2
	x4
	x4
	x2

	S2	1:1
--	----	-----

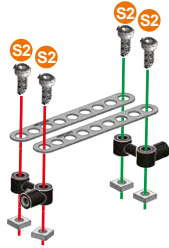

5 ③ + ④ +

	S2	9,5 mm 3/8"	x4
	S2		x4

	S2	1:1
--	----	-----

7

	x1
	x2
	x2
	x2
	x2
	x2
	x2

	C1	32mm 1 1/4"	x2
--	----	----------------	----

	x2
	x2
	x2

	C1	1:1
--	----	-----

A338

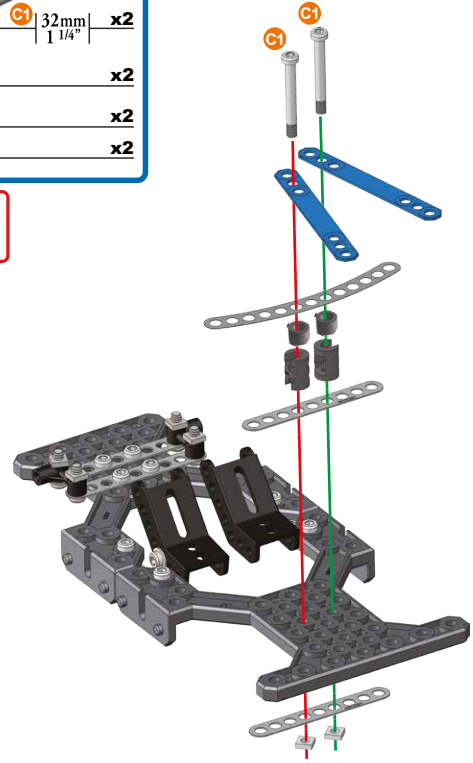

6

	x1
	x2
	x2
	x2

	S3	12 mm 1/2"	x2
--	----	---------------	----

	D277	1:1
--	------	-----

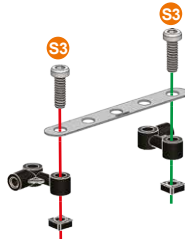

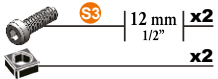
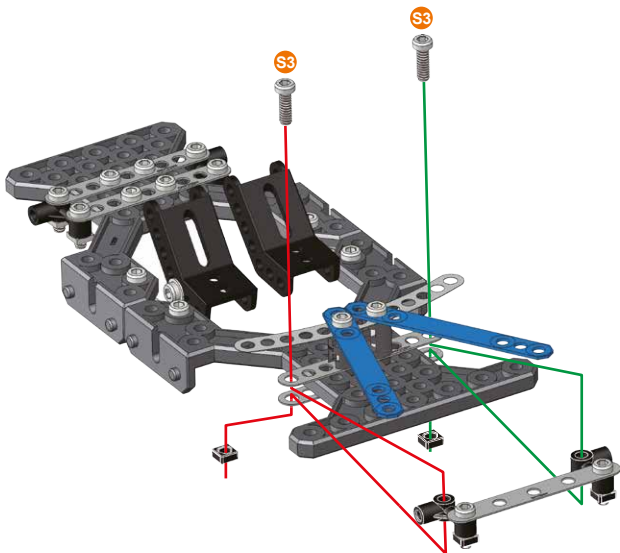
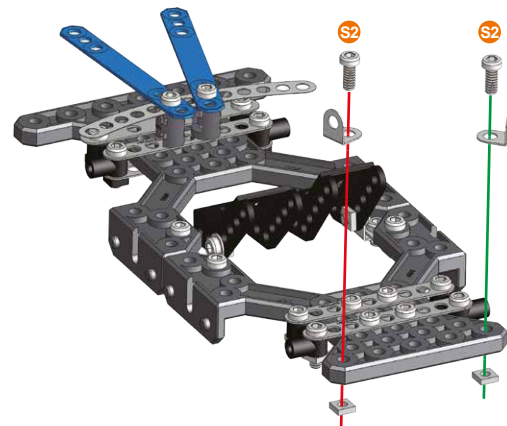
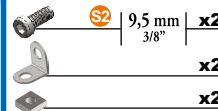
8**⑥ + ⑦ +****1:1****9**

10

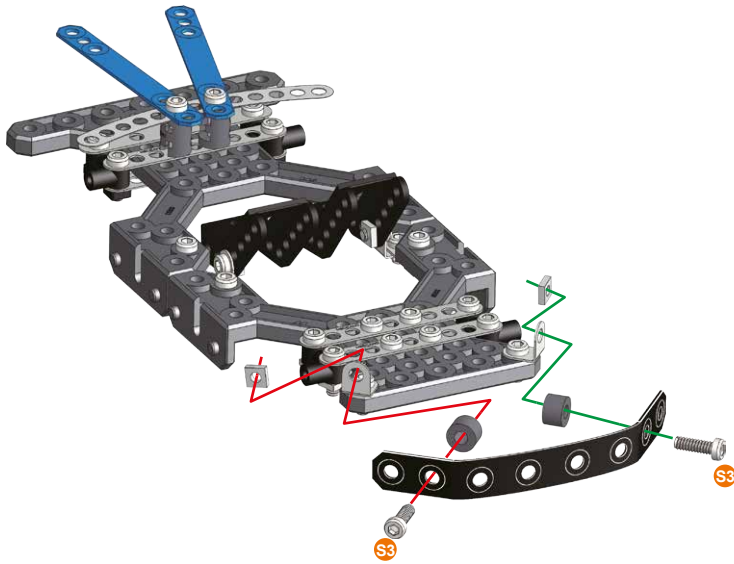
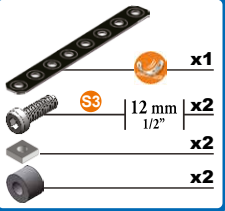

11

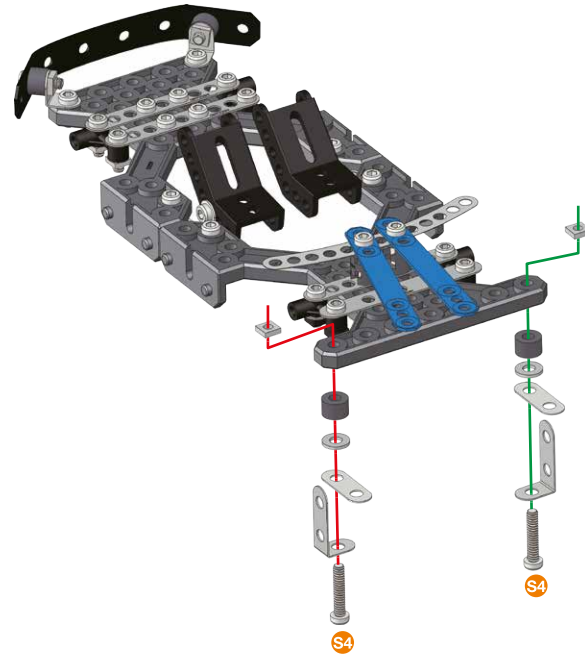
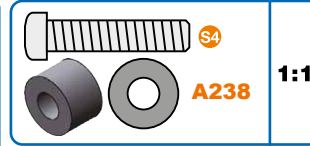
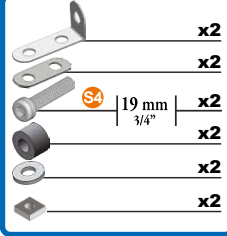

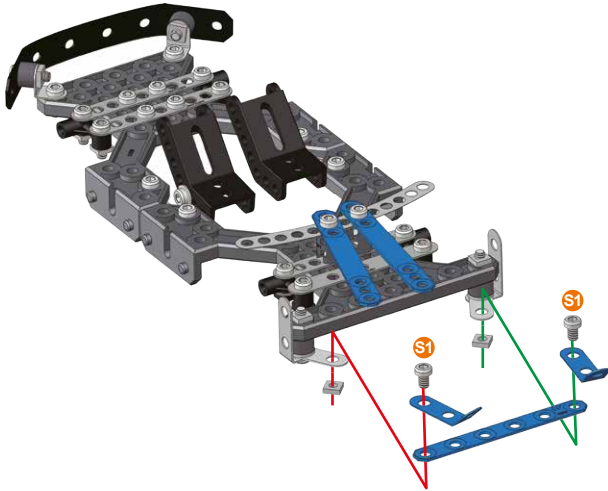
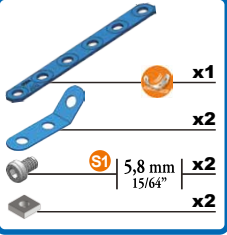
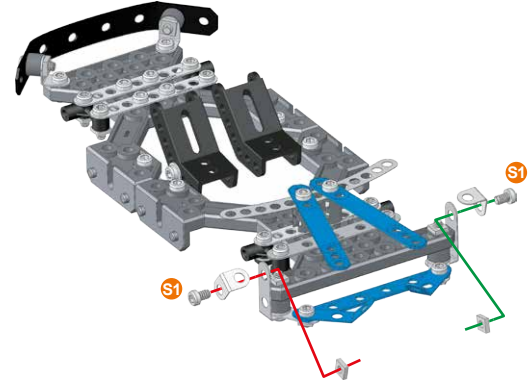
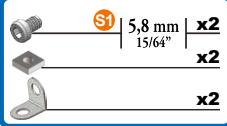
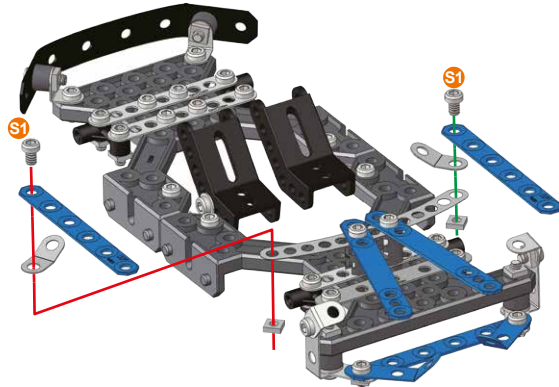
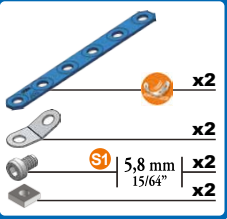
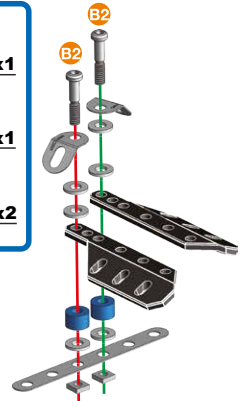
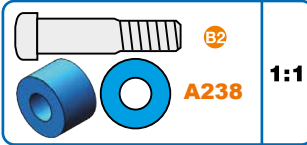
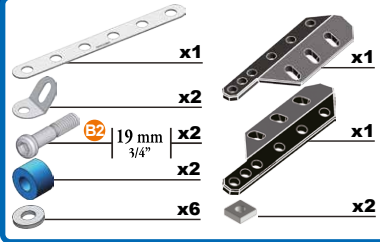
12**13****14****15**

16

	x1
	x1
	x3

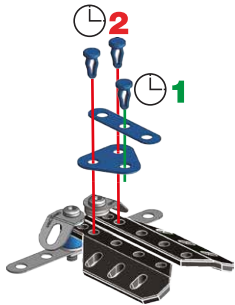

17

	x2
	x2
	x2
	x2

	S3	1:1
	A238	

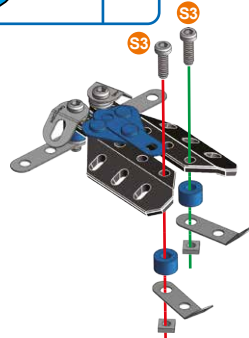

19 ⑭+ ⑱+

	B4 38,1 mm 1 1/2"	x2		x1
		x2		x1
		x2		x2
		x6		x2



	B4	1:1
	A238	

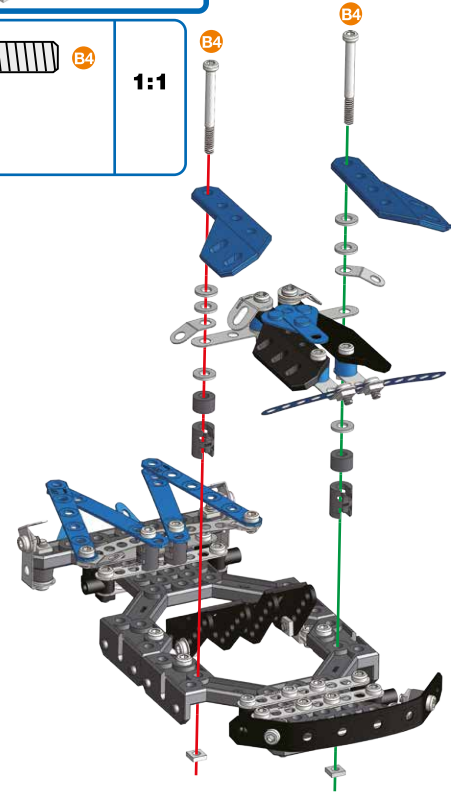





18

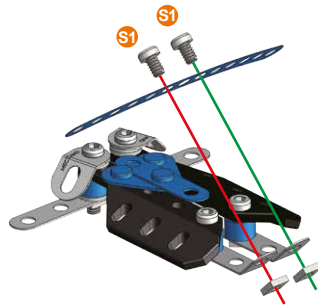

	x1	
	S1 5,8 mm 15/64"	x2
		x2

	S1	1:1
--	----	-----



20



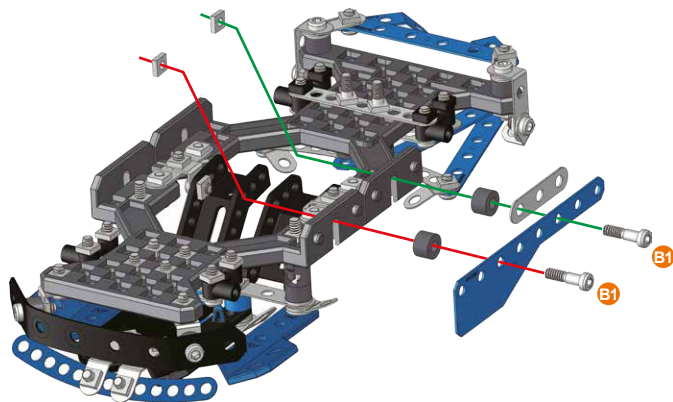

-  **x1**
-  **B1** | 14,7 mm | $\frac{37}{64}$ " **x2**
-  **x1**
-  **x2**
-  **x2**

-  **B1**
-  **A238**



1:1



21

-  **x1**
-  **B1** | 14,7 mm | $\frac{37}{64}$ " **x2**
-  **x1**
-  **x2**
-  **x2**



-  **B1**
-  **A238**

1:1

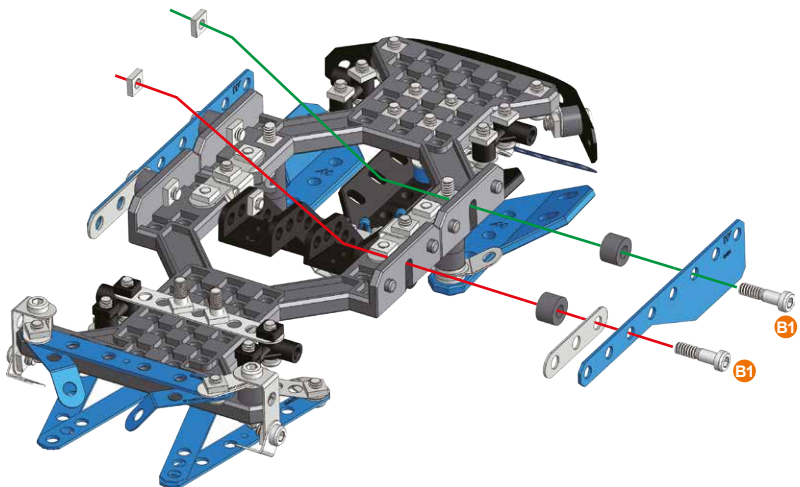



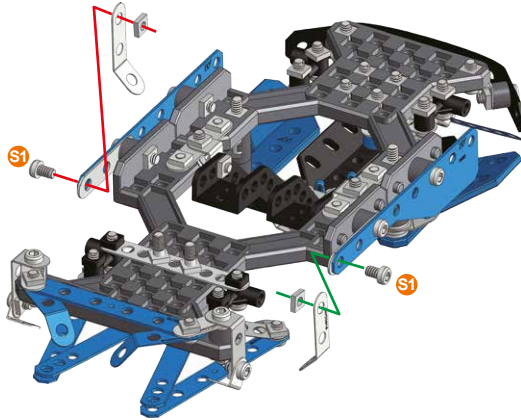
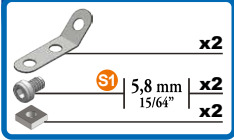

22

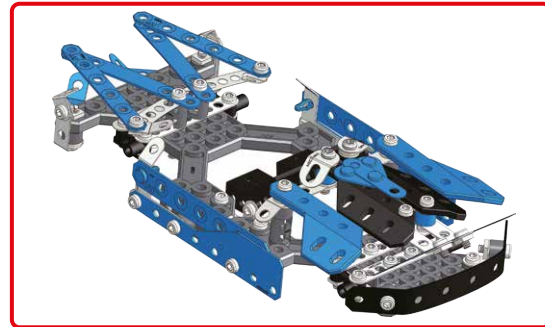
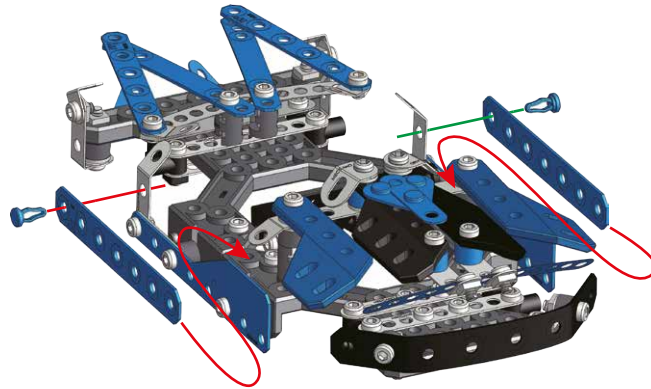
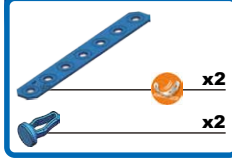

23

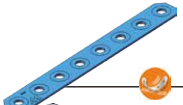



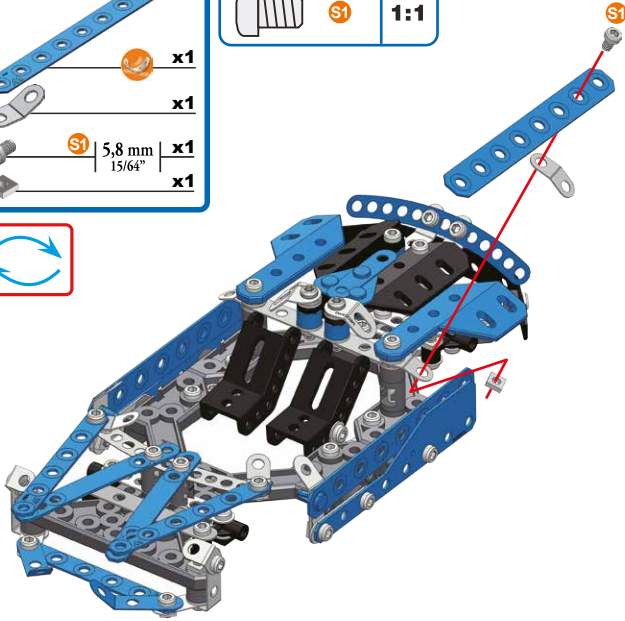

24

-  **x1**
-  **x1**
-  **x1**
-  **x1**

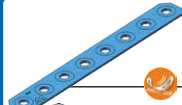



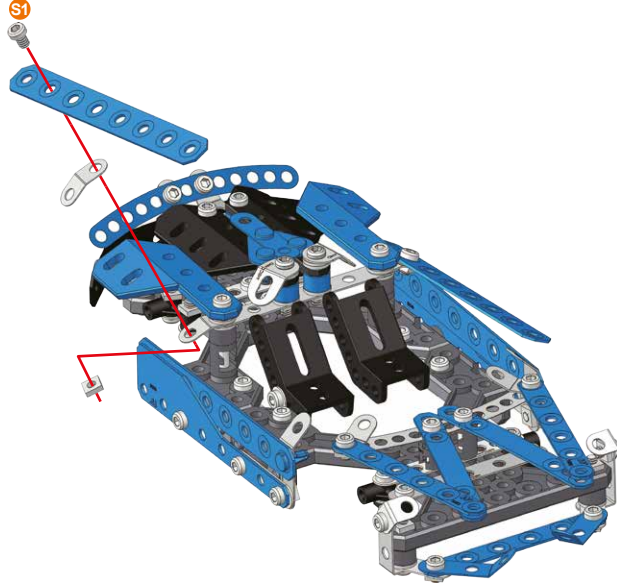

25

-  **x1**
-  **x1**
-  **x1**
-  **x1**



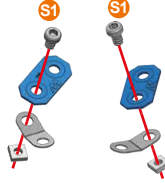

26

-  **x2**
-  **x2**
-  **x2**
-  **x2**





27 (25) + (26) +

 S1	5,8 mm 15/64"	x1
		x1

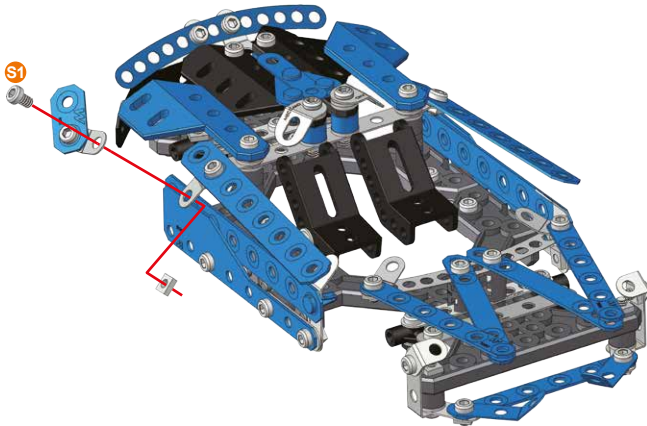
	S1	1:1
---	----	-----



28 (26) + (27) +

 S1	5,8 mm 15/64"	x1
		x1



	S1	1:1
---	----	-----

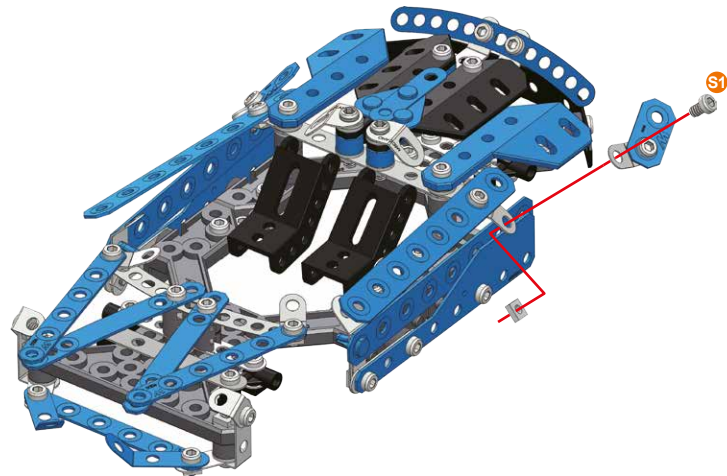



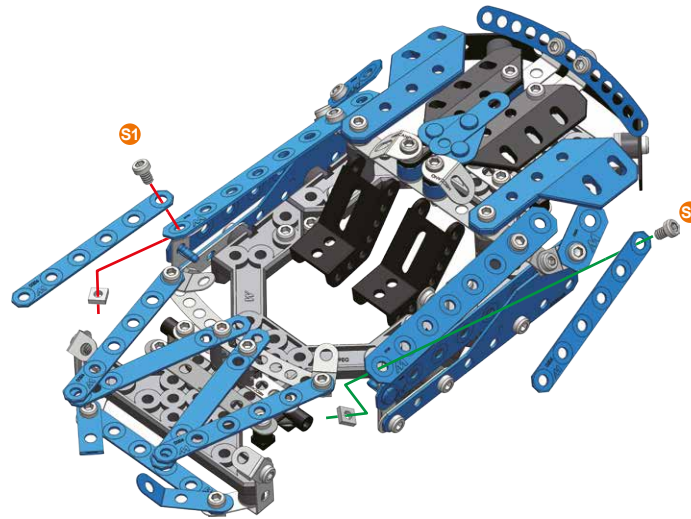
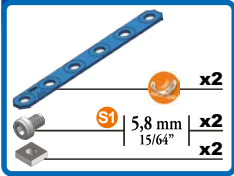

29

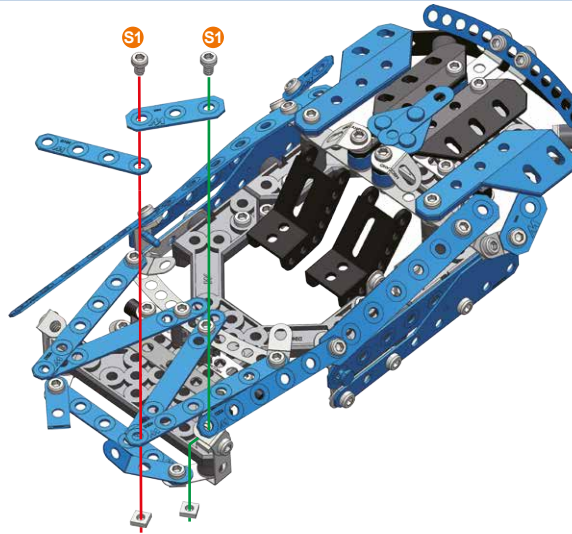
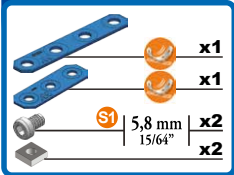

30





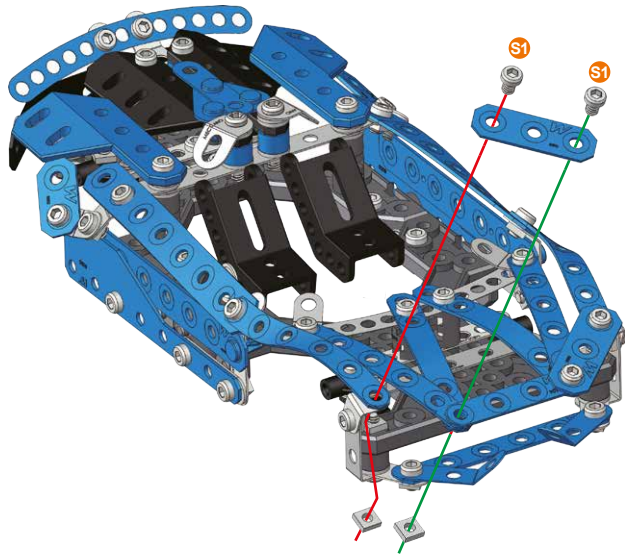

31

		x1
	 5,8 mm 15/64"	x2
		x2

		1:1
---	---	------------



32

	x1
	x2
 5,8 mm 15/64"	x2
	x2
	x2

		1:1
---	---	------------

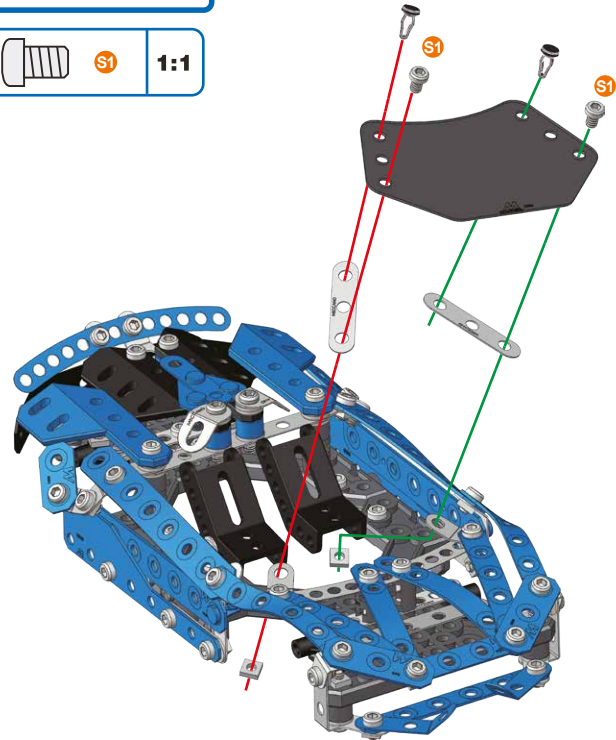

33



x2



34

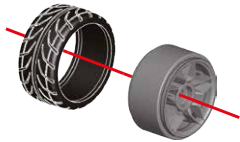



x2

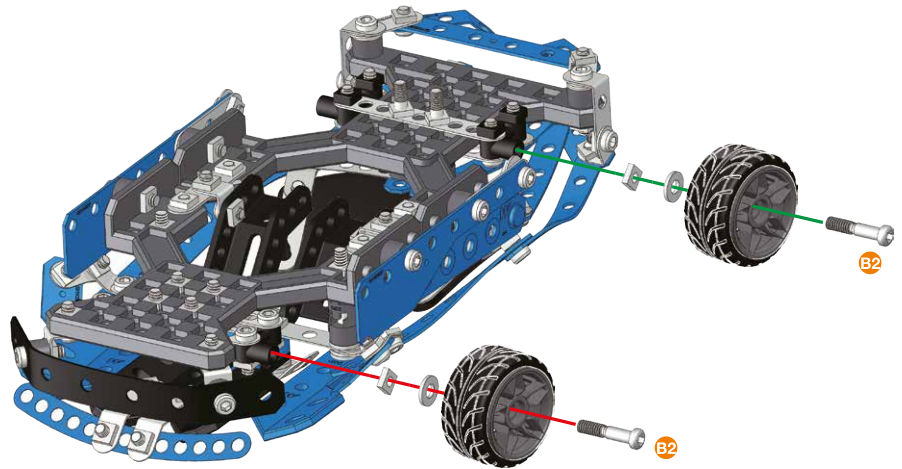
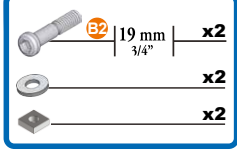

35



36 (34) + (35) +

	19 mm 3/4"	x2
		x2
		x2



	1:1
---	------------

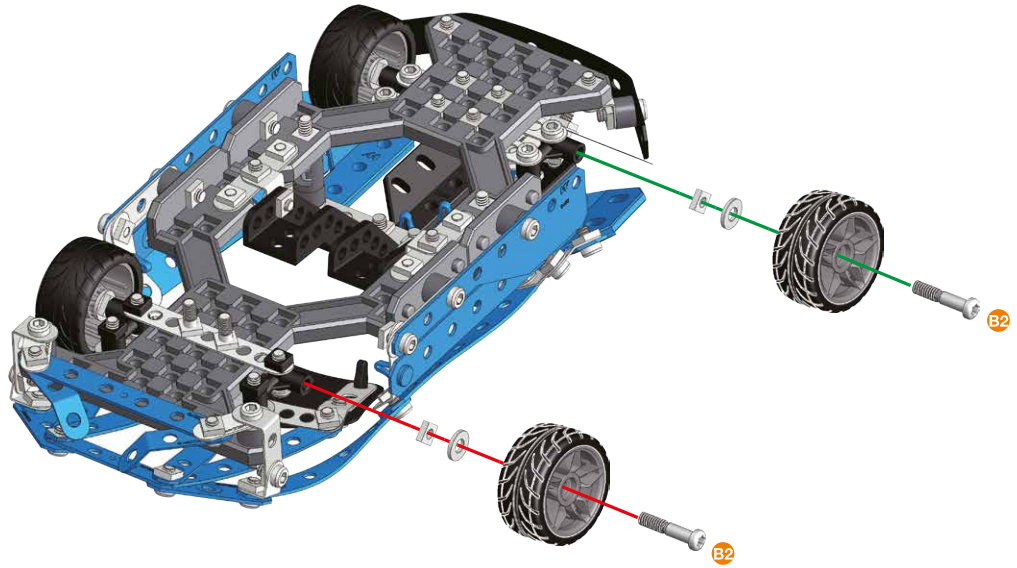

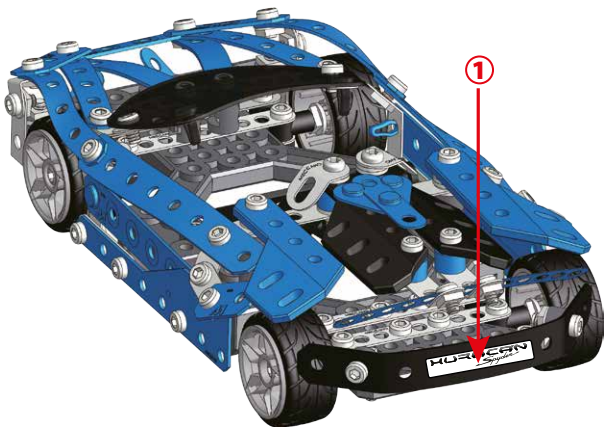

37

 ①	x1
---	----



38

 ②	x1
 ③	x1
 ④	x1

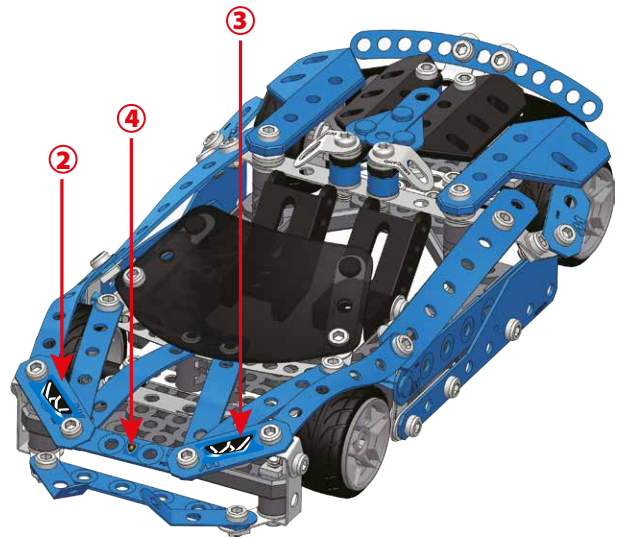

	D260 x1
	D259 x1
	D306 x1
	D051 x1
	D052 x1
	D252 x1
	D250 x1
	C887 x2
	D247 x4
	D311 x4
	D292 x4
	A423 x4
	D277 x4
	D005 x5
	D005 x2

	D126 x1
	D126 x2
	D109 x2
	D206 x5
	D303 x2
	D210 x2
	C779 x1
	C779 x1
	A413 x1
	C771 x4
	A235 x1
	D104 x1
	A416 x1
	A416 x6
	A437 x2
	A437 x4
	A812 x2
	A277 x1
	D205 x2
	D305 x2
	C330 x6
	A712 x2
	C483 x8
	A806 x2
	A238 10
	A238 x4
	A338 x2

	38,1 mm	B696 x2
	1 1/2"	
	32 mm	C935 x2
	1 1/4"	
	19 mm	A447 x6
	3/4"	
	19 mm	A911 x2
	3/4"	
	14,7 mm	A247 x4
	37/64"	
	12 mm	A411 x8
	1/2"	
	9,5 mm	A511 x14
	3/8"	
	5,8 mm	A637 x28
	15/64"	A138 x18
		A337 x62

x1

	C994 x1
	C993 x1

EN. Remove all packaging before use. Retain this information, addresses and phone numbers for future reference. Content may vary from pictures. Meccano reserves the right to discontinue the website www.meccano.com at any time. An adult should periodically check this toy to ensure no damage or hazards exist, if so, remove from use. Children should be supervised during play.

FR. Retirer tout l'emballage avant utilisation. Conserver les informations, adresses et numéros de téléphone pour consultation ultérieure. Le contenu peut différer des images. Meccano se réserve le droit de supprimer le site Internet www.meccano.com à tout moment. Le contenu peut différer des images. Un adulte doit régulièrement examiner ce jouet afin de s'assurer qu'il ne présente pas de dommage ni de risque. En cas de problème, ne plus l'utiliser. Les enfants doivent être surveillés lorsqu'ils jouent.

ES. Retire todo el embalaje antes de utilizar el producto. Conserve toda la información, las direcciones y los números de teléfono para futuras referencias. El contenido del paquete puede no corresponder con las imágenes. Meccano se reserva el derecho a suspender el sitio web www.meccano.com en cualquier momento. Un adulto debe revisar de forma periódica el juguete para asegurarse de que no supone un riesgo para el niño; si así fuera el caso, interrumpa su uso. Supervise a los niños mientras juegan con el producto.

DE. Entfernen Sie vor der Benutzung sämtliche Verpackungsmaterialien. Alle Informationen, Adressen und Telefonnummern bitte für mögliche Rückfragen aufbewahren. Der Packungsinhalt kann von den Bildern abweichen. Meccano behält sich das Recht vor, den Betrieb der Website www.meccano.com jederzeit einzustellen. Ein Erwachsener sollte regelmäßig sicherstellen, dass das Spielzeug keine Gefahr darstellt, und es gegebenenfalls entfernen. Kinder sollten beim Spielen beaufsichtigt werden.

NL. Verwijder de verpakking voor gebruik. Bewaar deze informatie, adressen en telefoonnummers voor toekomstig gebruik. Inhoud kan afwijken van illustraties. Meccano behoudt zich het recht voor de website www.meccano.com wanneer gewenst buiten gebruik te stellen. Een volwassene dient dit speelgoed regelmatig te controleren. In geval van schade of gevaaren het speelgoed niet meer gebruiken. Houd toezicht als kinderen spelen.

IT. Rimuovere l'imballo prima dell'uso. Conservare informazioni, indirizzi e numeri di telefono per riferimento futuro. Il prodotto potrebbe essere differente dalle immagini. Meccano si riserva il diritto di rimuovere il sito www.meccano.com in qualsiasi momento. Il giocattolo deve essere periodicamente controllato da un adulto per prevenire eventuali danni o rischi; in caso di danno, sospendere l'uso. I bambini devono essere sorvegliati durante il gioco.

PT. Remova totalmente a embalagem antes de utilizar. Guarde todos os endereços, números de telefone e demais informações para consulta e referência. O conteúdo poderá ser diferente das ilustrações. A Meccano reserva-se o direito de descontinuar o site www.meccano.com a qualquer altura. Um adulto deve verificar o brinquedo periodicamente para garantir que não há danos ou riscos. Se houver, é necessário que o brinquedo seja retirado de uso. As crianças devem ser supervisionadas enquanto brincam.

RU. Снимите все упаковочные материалы перед использованием. Запишите указанные на упаковке адреса и номера телефонов, чтобы у вас была возможность связаться с нами. Содержимое упаковки может отличаться от иллюстраций. Компания Meccano оставляет за собой право прекратить использование сайта www.meccano.com в любое время. Взрослым следует время от времени проверять игру и следить за тем, чтобы она не была сломана и не представляла опасности для ребенка. В противном случае ее не следует использовать. Во время игры дети должны находиться под присмотром.

PL. Przed użyciem wyjąć zabawkę z opakowania. Zachować niniejsze informacje, adresy i numery telefonów na wypadek, gdyby były potrzebne w przyszłości. Zawartość opakowania może różnić się od zabawki przedstawionej na obrazkach. Firma Meccano zastrzega sobie prawo do zaprzestania korzystania z witryny www.meccano.com w dowolnym momencie. Osoba dorosła powinna regularnie sprawdzać zabawkę pod kątem uszkodzeń oraz zagrożeń. Jeśli takowe wystąpią, należy zaprzestać używania zabawki. Dzieci nie powinny bawić się bez nadzoru.

CZ. Před použitím odstraňte veškeré balící materiály. Uložte si tyto informace, adresy a telefonní čísla pro budoucí použití. Obsah se může lišit od obrázků. Společnost Meccano si vyhrazuje právo kdykoli ukončit web www.meccano.com. Dospělá osoba by měla pravidelně kontrolovat, zda hračka není poškozená nebo zda nepředstavuje nebezpečí. Pokud ano, hračku vyhodte. Během hry nenechávejte děti bez dozoru.

SK. Pred použitím odstráňte všetok obalový materiál. Tieto informácie, adresy a telefónne čísla si uchovajte na ďalšie použitie. Obsah sa môže líšiť od zobrazenia. Spoločnosť Meccano si vyhradzuje právo kedykoľvek ukončiť používanie webovej lokality www.meccano.com. Túto hračku musí pravidelne kontrolovať dospelá osoba, aby sa uistila, že nedošlo k jej poškodeniu a že nehrozí žiadne nebezpečenstvo. Ak ano, ukončíte jej používanie. Deti nesmú byť pri hre bez dozoru.

HU. Használat előtt távolítsa el minden csomagolóanyagot. A tudnivalókat, a címet és a telefonszámot őrizze meg későbbi használatra. A csomag tartalma eltérhet a képen látottaktól. A Meccano fenntartja magának a jogot, hogy bármikor felfüggeszse a www.meccano.com weboldal használatát. A felnőtteknek rendszeresen ellenőrizniük kell, hogy a játékon nincs-e sérülés, illetve nem jelent-e veszélyforrást. Ha igen, ki kell vonni a használatból. A gyermeknek játék közben felügyeletet igényelnek.

RO. Îndepărtați toate ambalajele înainte de utilizare. Păstrați aceste informații, adresele și numerele de telefon pentru consultare ulterioară. Conținutul poate fi diferit de imaginea din fotografii. Meccano își rezervă dreptul de a întrerupe utilizarea site-ului web www.meccano.com în orice moment. Această jucărie trebuie verificată periodic de un adult pentru a se asigura că nu există nicio deteriorare sau niciun pericol; dacă există, scoateți jucăria din uz. Copiii trebuie supravegheați în timp ce se joacă.

TM & © 2016 MECCANO for packaging, instructions and models built with this set. *MECCANO is an exclusive trademark of MECCANO. Spin Master logo is a trademark of Spin Master Ltd. All rights reserved. / TM & © 2016 MECCANO pour l'emballage, les notices et modèles de ce coffret. * MECCANO est une marque de commerce exclusive de MECCANO. Le logo de Spin Master est une marque de commerce de Spin Master Ltd. Tous droits réservés.

- ⚠ WARNING: CHOKING HAZARD - Small parts.
- ⚠ ATTENTION ! DANGER D'ÉTOUFFEMENT - Contient de petits éléments.
- ⚠ ADVERTENCIA: PELIGRO DE ASFIXIA - Contiene piezas pequeñas.

- No conviene para niños menores de tres años.
- ⚠ ACHTUNG: ERSTICKUNGSGEFAHR - Kleinteile.
- ⚠ WAARSCHUWING: VERSTIKKINGSGEVAAR - Kleine onderdelen.
- ⚠ AVVERTENZA: RISCHIO DI SOFFOCAMENTO - Pezzi piccoli.
- ⚠ ATENÇÃO: PERIGO DE ASFIXIA - Peças pequenas.
- ⚠ ВНИМАНИЕ! ОПАСНОСТЬ УДУШЬЯ - Мелкие детали.
- ⚠ OSTRZEŻENIE: NIEBEZPIECZENSTWO ZADŁAWIENIA - Drobne elementy.
- ⚠ UPOZORNENÍ: NEBEZPEČÍ UDUŠENÍ - Obsahuje malé části.
- ⚠ UPOZORNENÍ: NIEBEZPEČENSTVO UDUŠENIA - Obsahuje malé predmety.
- ⚠ FIGYELMEZTETÉS: FULLADÁSVEZÉLY - Apró alkatrészek.
- ⚠ AVERTISMENT: PERICOL DE ASFIXIERE - Piese mici.



 The trademarks, copyrights and design rights in and associated with Automobili Lamborghini, Automobili Lamborghini with Bull and Shield Device and the following Lamborghini vehicle Huracán LP 610-4 Spyder are used under license from Automobili Lamborghini S.p.A., Italy

Les marques de commerce, droits d'auteur et droits de conception concernant/associés à Automobili Lamborghini, Automobili Lamborghini et son logo bouclier au taureau, ainsi que le véhicule Lamborghini Huracán LP 610-4 sont utilisés sous licence d'Automobili Lamborghini S.p.A., Italie.

Edad Recomendada 10 Años en Adelante Juguete Importado por: Spin Master México, S.A. de C.V. Av. Insurgentes Sur No.1070 piso 8 Colonia Insurgentes San Borja Delegación Benito Juárez C.P. 03100, Ciudad de México. R.F.C. SMM050627V48 Atención al cliente: 55 4160 7947

Meets CPSC Safety Requirements.
Conforme aux exigences de sécurité de la CPSC.
Cumple con las normas de seguridad de la CPSC.



SPIN MASTER LTD., 450 FRONT STREET WEST, TORONTO, ON M5V 1B6 CANADA.
Imported into EU by SPIN MASTER INTERNATIONAL, S.A.R.L.,
16 AVENUE PASTEUR, L-2310, LUXEMBOURG. www.spinmaster.com

T91837_0001_20084600_GML_IB_R20_MEC_Huracan_CN_S17

 **UK – 0800 206 1191, serviceuk@spinmaster.com**
IRELAND – 1800 992 249
FRANCE – 0800 909 150, servicefr@spinmaster.com
DEUTSCHLAND – 0800 0101 0222, kundenservice@spinmaster.com
SCHWEIZ – 0800 561 350 • ÖSTERREICH – 0800 297 267
NEDERLAND – 0800 022 3683, klantenservice@spinmaster.com
BELGIË/BELGIQUE – 0800 77 688 • LUXEMBOURG – 800 2 8044

ITALIA – 800 788 532, servizio@spinmaster.com
MÉXICO – 55 4160 7947, servicio@spinmaster.com
POLSKA – 800080238, poland@spinmaster.com
ČESKÁ REPUBLIKA – 800550530, czechrepublic@spinmaster.com
SLOVENSKO – 0800232800, slovakia@spinmaster.com
MAGYARORSZÁG – 080 100 052, hungary@spinmaster.com
ROMÂNIA – 0800400015, romania@spinmaster.com

NORTH AMERICA • AMÉRIQUE DU NORD 1-800-622-8339, CUSTOMERCARE@SPINMASTER.COM WWW.SPINMASTER.COM